



AK SIDE FOLDING STOCK FOR STRAIGHT TANG RECEIVER

USER MANUAL

FEATURES & SPECIFICATIONS

- Impact & Heat Resistant Glass Fiber-reinforced Matte Black Polymer Construction
- Folds to the Right for Compatibility with Side-mounted Optics
- Solid Retention while Folded, Locks into Place when Deployed, and Unlocks via Reinforced Push-button
- Adjustable 5 Position Length of Pull (LOP) with Spring-loaded Deployment
- LOP Adjustment can be Configured to Deploy Directly to User's Preferred Position upon Spring-loaded Deployment
- Installs with no Permanent Modification
- Angled and Rubberized Nonslip Butt Pad
- QD Sling Swivel Housings at the Rear and Front of the Stock
- Counted as One U.S. Made Part for the Firearm Subject to 18 U.S.C. § 922(r)
- US PAT. 11067360, US PAT. 11592264, US PAT. 11598604

RBU47FS01	
Platform	Stamped AK with Straight Tang
LOP Collapsed	13.59" (345 mm)
LOP Extended	16.42" (417 mm)
LOP Adjustment Increment	5 Positions 0.71" (18 mm) per Position
Material	Glass Fiber-reinforced Polymer
Dimensions	10.62" x 1.95" x 5.43" (270 x 50 x 138 mm)
Weight	19.65 oz (557 g)

OVERVIEW

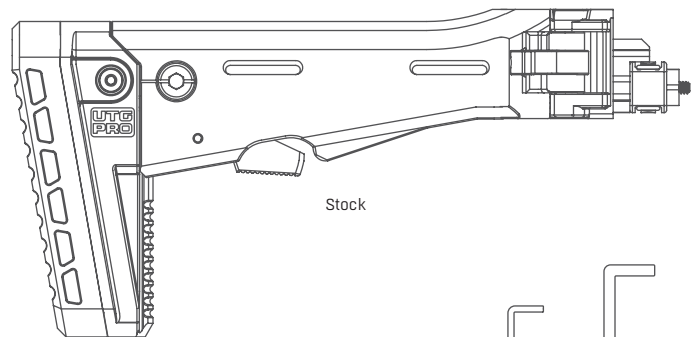

STOCK INSTALLATION

⚠ WARNING: Ensure the firearm is clear of all ammunition. Confirm the chamber is empty and the magazine is removed. Always follow all firearm safety rules.



Before installation, begin by removing the original stock, dust cover, and guide rod spring.
To begin installation, press the side button to unfold your AK Side Folding Stock.



With the stock now open, insert the base (folding adaptor) into the receiver until flush.



Hold the folding adaptor flush in place to the receiver. Use the 3 mm Hex Key to tighten the inner screw CLOCKWISE. Tighten until the screw no longer spins. Do not forcefully overtighten or it will create a gap.



Self-tapping Screw

The 1/2 inch Self-tapping Screw is included to secure the folding adaptor hinge base to the inside of the firearm. Ensure the adaptor stays flush against the receiver as this will fix your stock. (Optional: Drill a 1/16 inch hole into the folding adaptor. Do not exceed a 1/2 inch depth.)

QD SLING SWIVEL SOCKET INSTALLATION

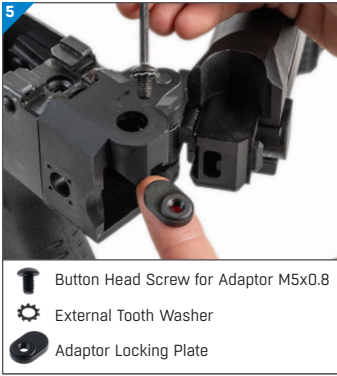

With the hinge still open to the folded position, place the Adaptor Locking Plate with the long end forward and the flat end down. Thread on the screw through the top using the 3 mm Hex Key, with the External Tooth Washer, until the screw is seated.



Installation is now complete. The firearm is now ready to for reassembly. Perform function check before use.



The stock comes with two QD Sling Swivel Sockets on the left side: one towards the front and a second preinstalled towards the rear. The rear QD Sling Swivel Socket is user configurable for both right and left side mounting.



To reconfigure the rear QD Sling Swivel Socket mounting side:
Unscrew and remove the socket hardware. Reinsert the QD Socket into the desired side. Insert the screw into the QD Socket and tighten the nut into the hole on the opposite side.

ADJUSTING THE LENGTH OF PULL



The stock has a total of 5 length positions. Pressing the button will cause the stock to quick deploy to the maximum or preset in-between position. The stock comes from the factory with the longest maximum position as default.



To adjust the length shorter from the maximum position, depress the lever and push the butt pad inward. Release the lever at your desired position.

PRESETTING YOUR LENGTH OF PULL

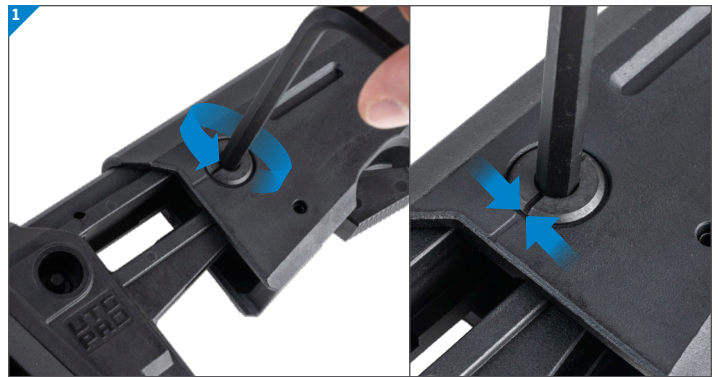

To change your maximum length of pull for quick deploy, first adjust your length of pull to the desired position.

Then use the included 6 mm Hex Key to turn the "maximum length of pull limit screw" COUNTERCLOCKWISE until the spinning stops. Do not force it. If the indicator lines on the body and screw do not line up, back it out slightly until they do.

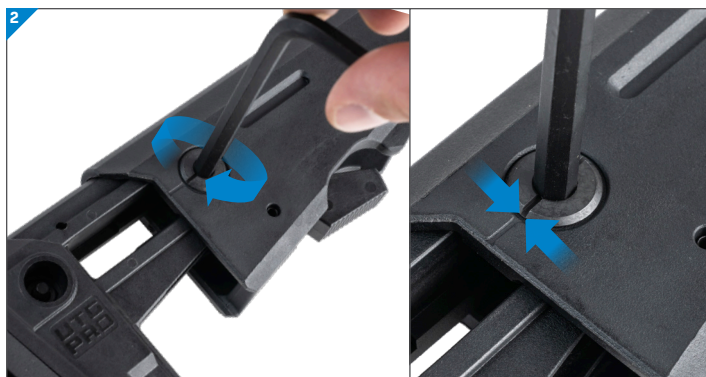

Once your maximum length of pull has been preset, you may want to change it again. The easiest method is to reset your length of pull to the maximum factory setting.

Use the 6 mm Hex Key to turn the "maximum length of pull limit screw" CLOCKWISE fully until the spinning stops. Do not force it. If the indicator lines on the body and screw do not line up, back it out slightly until they do.

Repeat above preset steps for your new desired length of pull.

THE BEST NEVER REST WARRANTY - LIFETIME

LEAPERS® warrants that all products conform to published specifications and are free from defects in material and workmanship. Leapers, Inc. will repair or replace a defective product for the duration of the product's life span. Verification through a Return Authorization (RA) number is required. If the product is discontinued, credit in the amount of the product's MSRP may be applied toward a replacement item.

Note: Our warranty does not extend to theft, loss, deliberate, accidental, or cosmetic damages, negligence, misuse, disassembly beyond normal maintenance, or any unauthorized repair or alteration.

Please take caution when purchasing products on the secondary market. A LEAPERS® product that is purchased secondhand is always at the buyer's own risk. We cannot guarantee that the product you purchased is genuine without a serial number or complete with all necessary parts unless returned and inspected.

LEAPERS® reserves the right to confiscate counterfeit products based on our intellectual property rights and usage and always recommends purchasing LEAPERS® products through reputable retailers.

Please feel free to call us at (734) 542-1500 or email us at office@leapers.com. You may submit a customer service inquiry via our website at www.leapers.com/contact or a warranty request at www.leapers.com/support/lifetime-warranty.

