

MUF019011201

 **COMBAT
RED LASER**
UTG® Unleash The Glow





BULL DOT™

LASER SIGHT

FOR MODEL: SCP-LS288





MULTI-APPLICATION



LAW ENFORCEMENT



HUNTING



HOME DEFENSE

EXPANDED LASER DOT SIGHT

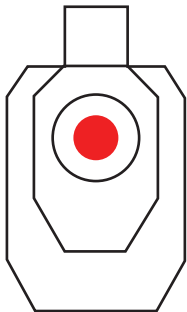

10
YARDS

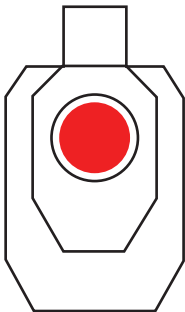

30
YARDS

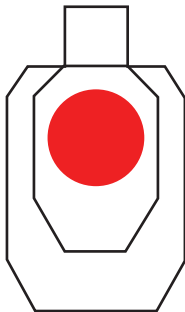

50
YARDS



CAUTION!

If you need to mount the laser sight onto a firearm, make sure firearm is not loaded before installation. Remove magazine and examine chamber.

Always use safe handling procedures at all times.

Avoid direct eye exposure to laser beam and keep out of reach of children.

Do not direct laser beam toward any person, aircraft, public transportation or other objects with safety concerns.

Examine battery quality and appearance before use each time and make sure that there is no leaking or any deformation. Dispose appropriately if there is a problem.

The batteries are pre-charged by the manufacturer, and cannot be recharged. Recharging can cause battery leakage or, in some cases, high-pressure rupture. Inadvertent charging can occur if a battery is installed backwards.

Install batteries by aligning the + and – signs marked on the battery with the + and – signs marked on the battery chamber in the laser sight.

Never use non-rechargeable and rechargeable batteries together in a laser sight. Always replace batteries with the exact type and size specified for the laser sight.

Turn off the laser sight when not in use to conserve battery power.

Always remove batteries from laser sight after use. Leaving battery in the laser sight without use for long period of time may cause damage or danger.

Always replace the whole set of batteries at the same time. Never mix new and used batteries in the same laser sight.

Never deliberately short circuit batteries. Prolonged short circuit will cause the battery to lose energy and result in significant temperature increase.

Do not carry laser sight with batteries installed in the car trunk while driving.

Keep battery compartment clean and keep any metallic object away from the battery.

Lithium batteries can explode or cause burns if disassembled, shorted, recharged, exposed to water, fire, or high temperatures. Do not place loose batteries in a pocket, purse, or other container containing metal objects. Do not mix new with used batteries or mix required batteries with other types of battery. Do not store batteries with hazardous or combustible materials. Store in cool, dry, ventilated area. Follow applicable laws and regulations for disposal.



Avoid direct eye exposure and keep out of reach of children.
Do not direct laser beam toward any person, aircraft, public transportation or other objects with safety concerns.

Component Illustration

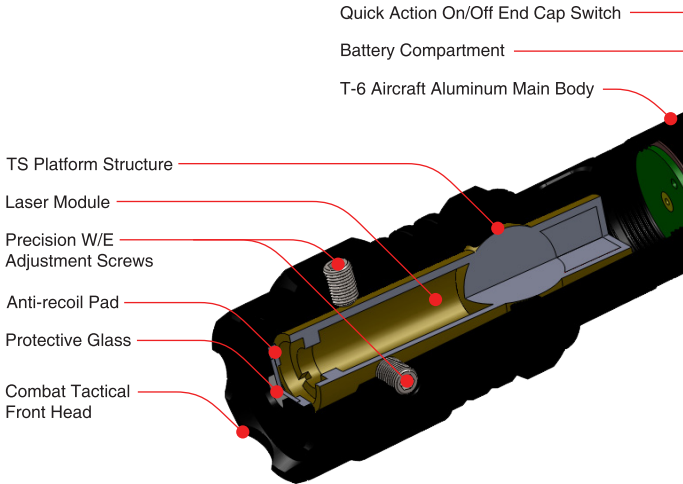

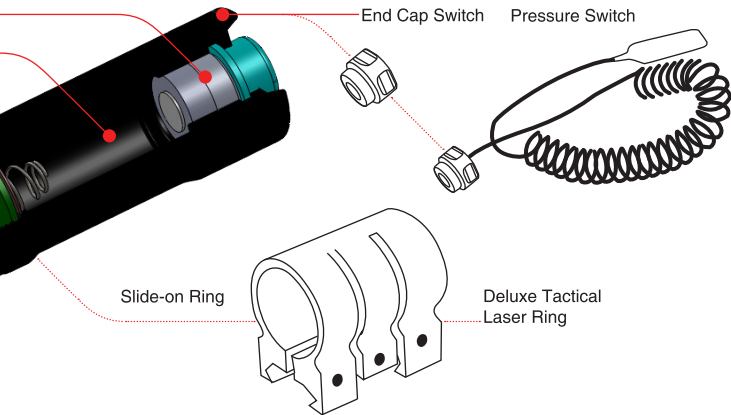

The purpose of this diagram is to provide a better understanding of the superior internal structure of the laser sight. Please do NOT disassemble the product which will void its warranty.

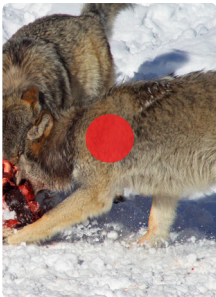

50 Yards
Laser Dot Diameter: 8"

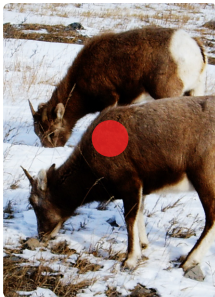

30 Yards
Laser Dot Diameter: 5"

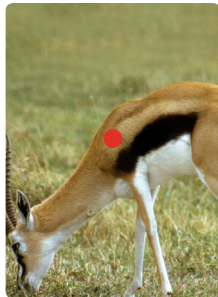

10 Yards
Laser Dot Diameter: 2"

- Enlarged Laser Dot for Quick Acquisition of Moving Target and Instant Shot Placement on Target's Vital Area
- Provides illumination Assistance for Better Shots Without Alerting the Target
- Laser Dot Expands with Increasing Distance for Rapid Sighting
- Ideal for Hunting, Law Enforcement, and Self Defense
- Revolutionary True Strength Platform and Smart Spherical Structure for Optimal Performance and Reliability
- Precise and Wide Range Windage/Elevation Adjustment
- High Quality Aircraft Grade Aluminum Construction and Hard Coat Finish



Specification

Item Number	SCP-LS288
Length	4.3"
Main Body Diameter	0.79"
Weight (with Battery)	3.2 oz
Structure & Adjustment	TS & 3 Points
W/E Adjustment Range	31.5" @ 11yds
Type	CLASS 3R

Output Power	2.0 - 3.0 mW
Wavelength	650nm
Beam Diameter	8" Dia. @50Yds
Operating Temperature	14°F ~ 104°F
Battery	CR2 Battery
Battery Operating Time	7 Hrs
Laser Beam Life Time	8000 hrs

Replacement Parts

Contact your flashlight distributor for the following replacement parts:

		
RG-LS269	BAT-LIT750	TL-PSLS279
Tactical Slide-on Ring	1 PC CR2 Lithium Battery	Pressure Switch

Instruction

Battery Installation

1. Unscrew the End Cap Switch or the Pressure Switch. Install 1 CR2 battery following the direction in (Fig-1).

Mounting the Laser

1. Slide the laser sight into the laser ring (Fig-2).
2. Slide the laser and ring onto the mount rail of the firearm or other application (Fig-3).
3. Use the provided Allen key to tighten the 2 side screws on the ring to ensure a firm grip of the laser ring on the rail (Fig-4).
4. Adjust the laser to establish proper positions for windage and elevation adjustment screws (Fig-5).
5. Tighten the middle screw on the ring to ensure a firm grip of the laser ring on the laser sight (Fig-6).

WARNING: Do not over tighten the screws which may cause damage to the laser sight body.

Two Operation Modes

1. On-off Switch Operation
 - a) Tighten the end cap switch.
 - b) Press and release the button in the center of the end cap switch to turn on or off the laser sight (Fig-7).
2. Pressure Switch Operation
 - a) Separate the end cap switch from the from the laser sight.
 - b) Replace the end cap switch with the pressure switch and tighten snugly.
 - c) Press and hold the pressure pad in the middle to turn on the laser sight. Release the pressure pad to turn off the laser sight (Fig-8).



Turn the laser to establish proper positions for windage and elevation adjustment screws.



Windage/Elevation Adjustment

Once the laser sight is mounted in position, the adjustment screw on the top or bottom of the laser becomes the elevation adjustment screw, and the adjustment screw on the side of the laser becomes the windage adjustment screw.

Stabilize the firearm to minimize any unexpected movement. Fire a test shot. If the impact point of the bullet is exactly in the center of the target, then the laser sight is zeroed. Otherwise, it needs to be adjusted based on the bullet impact. To move the laser beam upward/downward, use Allen wrench to rotate the elevation adjustment screw. To move the laser beam left/right, rotate the windage adjustment screw.

Keep test firing and adjusting until you achieve zero.

Elevation Adjustment:

To move the laser beam upward/downward









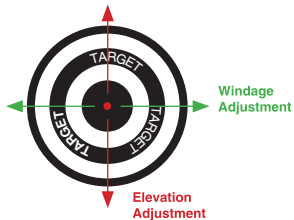

















End Cap Switch

Windage Adjustment:

To move the laser beam left/right



IMPACT POINT MOVEMENT INSTRUCTION		Adjustment Screw Positions (From Rear of Laser)			
					
W/E Adjustment		Bullet Impact Point Movement			
Windage					
					
Elevation					
					

Maintenance

Maintain the metal surface of the laser sight by removing any dirt or sand with a soft brush to avoid scratching the finish.

Store the laser sight in a cool dry place when not in use. Be careful to avoid contact with acid, alkaline or corrosive chemicals.

Take the battery out. This insures good working batteries for your laser and prevents battery leakage.

Keep a fresh package of batteries next to your laser. This gives you back-up power for your laser.

Do not store your laser sight in high temperatures. This would damage your laser sight and may result in battery leakage.

Do not attempt to lubricate any part of the laser sight.

Do not disassemble the laser sight other than replacing pressure switch. Do not loosen or remove screws or parts. Any such or similar actions will void the warranty.

The Best Never Rest Warranty - Lifetime

Leapers, Inc. warrants that all UTG & UTG PRO products conform to published specifications and are free from defects in material and workmanship. We will repair or replace defective products for the duration of the product's life span. Our dedicated and professional in-house customer service team will go above and beyond to make things right and provide the best in-class customer service experience you expect to receive.

Our warranty does not extend to products damaged from misuse, accidental damage, negligence, natural disasters/accidents, or unauthorized repair or alteration.

For warranty service, please submit your inquiry by visiting our customer service page on our website at www.leapers.com or give us a call at 734-542-1500. A Return Authorization Number (RMA) must be assigned before returning any products for warranty service.

Disclaimer and Limitation of Liability

Leapers is pleased to offer suggestions of the use of its products, however Leapers neither assumes responsibility for any omissions or errors nor assumes liability for any damages that result from the use of its products in accordance with information provided by Leapers, whether verbal or written.

EXCEPT FOR THE EXPRESS WRITTEN WARRANTY SPECIFICALLY SET FORTH ABOVE, ALL EXPRESS AND IMPLIED REPRESENTATIONS AND WARRANTIES ARE HEREBY DISCLAIMED, INCLUDING ANY IMPLIED WARRANTY OF MERCHANTABILITY, NON-INTERFERENCE, FITNESS FOR A PARTICULAR PURPOSE, NON-INFRINGEMENT, OR WARRANTY OF ACCURACY OF ANY INFORMATION PROVIDED WHETHER WRITTEN OR ORAL. ALL WARRANTIES ARISING FROM ANY COURSE OF DEALING, LAW, USAGE OR TRADE PRACTICE ARE HEREBY EXPRESSLY EXCLUDED TO THE EXTENT ALLOWED BY LAW. TO THE EXTENT AN IMPLIED WARRANTY CANNOT BE EXCLUDED, SUCH WARRANTY IS LIMITED IN DURATION TO ONE YEAR. SOME STATES OR JURISDICTIONS DO NOT ALLOW LIMITATIONS ON HOW LONG AN IMPLIED WARRANTY LASTS, SO THE ABOVE LIMITATION MAY NOT APPLY TO YOU.

UNDER NO CIRCUMSTANCES IS LEAPERS, OR ITS SUPPLIERS OR RESELLERS LIABLE FOR ANY OF THE FOLLOWING EVEN IF INFORMED OF THEIR POSSIBILITY: 1) THIRD PARTY CLAIMS AGAINST YOU FOR DAMAGES; 2) SPECIAL, INCIDENTAL, OR INDIRECT DAMAGES OR FOR ANY ECONOMIC CONSEQUENTIAL DAMAGES; OR 3) LOST PROFITS, BUSINESS REVENUE, GOODWILL, OR ANTICIPATED SAVINGS. SOME STATES OR JURISDICTIONS DO NOT ALLOW THE EXCLUSION OR LIMITATION OF INCIDENTAL OR CONSEQUENTIAL DAMAGES, SO THE ABOVE LIMITATION OR EXCLUSION MAY NOT APPLY TO YOU.